

EURONORM

DRIVE SYSTEMS

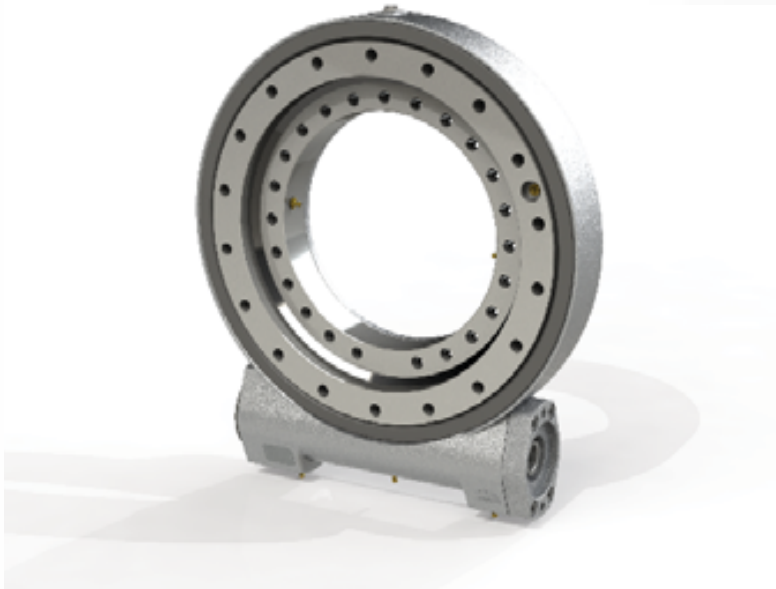

Slewing Drives Industrial

As an internationally operating supplychain partner, Euronorm is serving the European market with transmission components that present a more than convincing balance between price and quality.

Products

Euronorm distinguishes itself in the market by means of its extensive programme of electrical and mechanical transmission components. Thanks to an excellent interchangeability, high quality and competitive price level Euronorm transmissions are the first choice for both new constructions and the replacement market.

Service

Euronorm means direct contact with experienced technical specialists, good advice and no quibble agreements. The compact organisation makes it possible to give customers dedicated attention, which due to the personal nature of the firm relationships with a more than usual involvement during consultation, supply and support. Thanks to the Euronorm workshop, modification of transmissions to suit customer demands can be executed swiftly and reliably, be it a longer shaft for a motor or an alternative paint system or paint colour. Also a solid product support by means of good documentation, 3D drawings or the professional development and testing of prototypes is in capable and committed hands with Euronorm, and gives Euronorm its notable position in the transmission market.

Reliability of supply

In all respects Euronorm is a reliable partner, also when it comes to reliability of supply. Thanks to a generous and ambitious stock management and the in-house assembly of motors and reducers it is possible to realise short delivery times under the motto "to measure and to schedule".

Inhoud

| | |
|---|----|
| 1.Slewing drives characteristics | 4 |
| 2.Transport, handling and storage | 4 |
| 3.Installation | 5 |
| 4.Lubrication | 5 |
| 5.Maintenance / Security controls | 5 |
| Drawings | 6 |
| WD-7 | 6 |
| WEA-7 | 7 |
| WD-9 | 8 |
| WEA-9 | 9 |
| WD-14 | 10 |
| WEA-14 | 11 |
| WD-17 | 12 |
| WEA-17 | 13 |
| WD-19 | 14 |
| WEA-19 | 15 |
| WD-25 | 16 |
| WEA-25 | 17 |
| WD-37 | 18 |

1. Slewing drives characteristics

Slewing drives present some characteristics that should be taken into account to choose the proper series for each application. The main points to consider are the ones following:

- The maximum output speed must be around 2,5 rpm.
- The standard temperature working range of a slewing drive is established between -20 and 70°C.
- The slewing drives can be used both in horizontal and in vertical position. In case installing it in vertical position, please consult the Euronorm Technical department.
- The load diagrams for each drive show its limit static load with a safety factor of 1. Euronorm recommends adding an application factor to the loads according to the following table. To assure the drive chosen is the right one, the loadcase of the application must be below the limit curve.

| Application | Application criteria | Application factor |
|-----------------------------------|----------------------|--------------------|
| Casting | Extreme application | 1.5 |
| Machines for building / cranes | Extreme application | 1.25 |
| Vehicles and mounting on vehicles | Extreme application | 1.25 |
| Forklifts / Bulldozers | Light shocks | 1.1 |
| Treatment plants | Vibrations | 1.25 |
| Wind turbines | Danger of streaking | 2.0 |
| Robots | Rigidity | 1.25 |
| Antennas | Precision | 1.5 |
| Machines-tool | Precision | 1.5 |
| Measurement technique | Smooth operation | 2.0 |

The load diagrams are also limited by the bolts. They are only valid if all the bolts of the slewing drive are used to fix it to the structure. The quality of the bolts is considered grade 10.9, the threaded length should be at least 1.5 times the bolt diameter and the recommended flange thickness 2 times the bolt diameter. If the bolt curve does not appear in the chart, this means that this curve is above the slewing ring chart.

In case you have questions regarding the application for breach of any point of the ones mentioned above or various load cases are applied, we recommend contacting Euronorm Technical Department. In case the slewing drive chosen does not adapt to your application we recommend consulting the slewing ring catalogue, as there exist a major variety of products and features.

2. Transport, handling and storage

Transport only in horizontal position avoiding possible impacts. The vertical series should be transported and stored in vertical position. The slewing drive should be manipulated carefully and wearing working gloves all the time. The threaded holes can be used to fix bolts to handle the slewing drive in a safety way with a hoisting device. Store always in horizontal position and in closed rooms.

3. Installation

Previous to the installation, a cleaning of the slewing drive and the structure where is going to be mounted must be done. It is not allowed the use of steam high pressure systems. It should be checked that the slewing drive is fully supported by the structure. The supporting surface must accomplish some requirements considering a maximum flatness deviation. The slewing drive must be mounted without any external loads. It is convenient to perform working tests in the structure before the loads are applied. The bolts used must be from the dimension, quantity and quality indicated.

4. Lubrication

For all applications a proper lubrication is necessary for a smooth operation of the slewing drive. There are three parts that need to be lubricated: the slewing ring raceway, the screw worm and the bearings. The quantity of grease required is around 60cc for the screw worm, 10cc for each tapered roller bearing and 10cc each 250mm of diameter for the slewing ring raceway. The procedure to regrease consists in injecting grease into all grease nipples one after the other while rotating the slewing drive. The slewing drives must be regreased after each cleaning and also before and after large periods of inactivity.

Re-lubrication is needed to assure a minimum quality on the grease inside the drive. In case no comparative results are available, the following table can be used as a reference.

| Working conditions | Slewing Ring and Screw Worm Re-lubrication intervals |
|--|---|
| Rotational speeds <0,5rpm Non extreme environmental conditions (solar trackers) | Every 400 hours of operation or once every 12 months |
| Rotational speeds >0,5rpm Non extreme environmental conditions (man lift, industrial applications) | Every 200 hours of operation or once every 6 months |
| Extreme climatic conditions (sea / desert / Arctic climate / very dirty surrounding) (tunnelling machines/steel mills) | Every 100 hours of operation or once every 3 months |
| Bearing re-lubrication intervals | |
| All working conditions | Every 400 hours or every 12months |

To choose the proper type of grease for each application, please contact Euronorm technical department.

5. Maintenance / Security controls

Euronorm recommends retightening the bolts to the prescribed torque after no more than 100 working hours to compensate the possible settling. This should be done without external loads applied on the bolts union. This inspection should be repeated from then on every 3 months of working. The frequency of the inspection must be reduced under special working conditions.

WEA-7

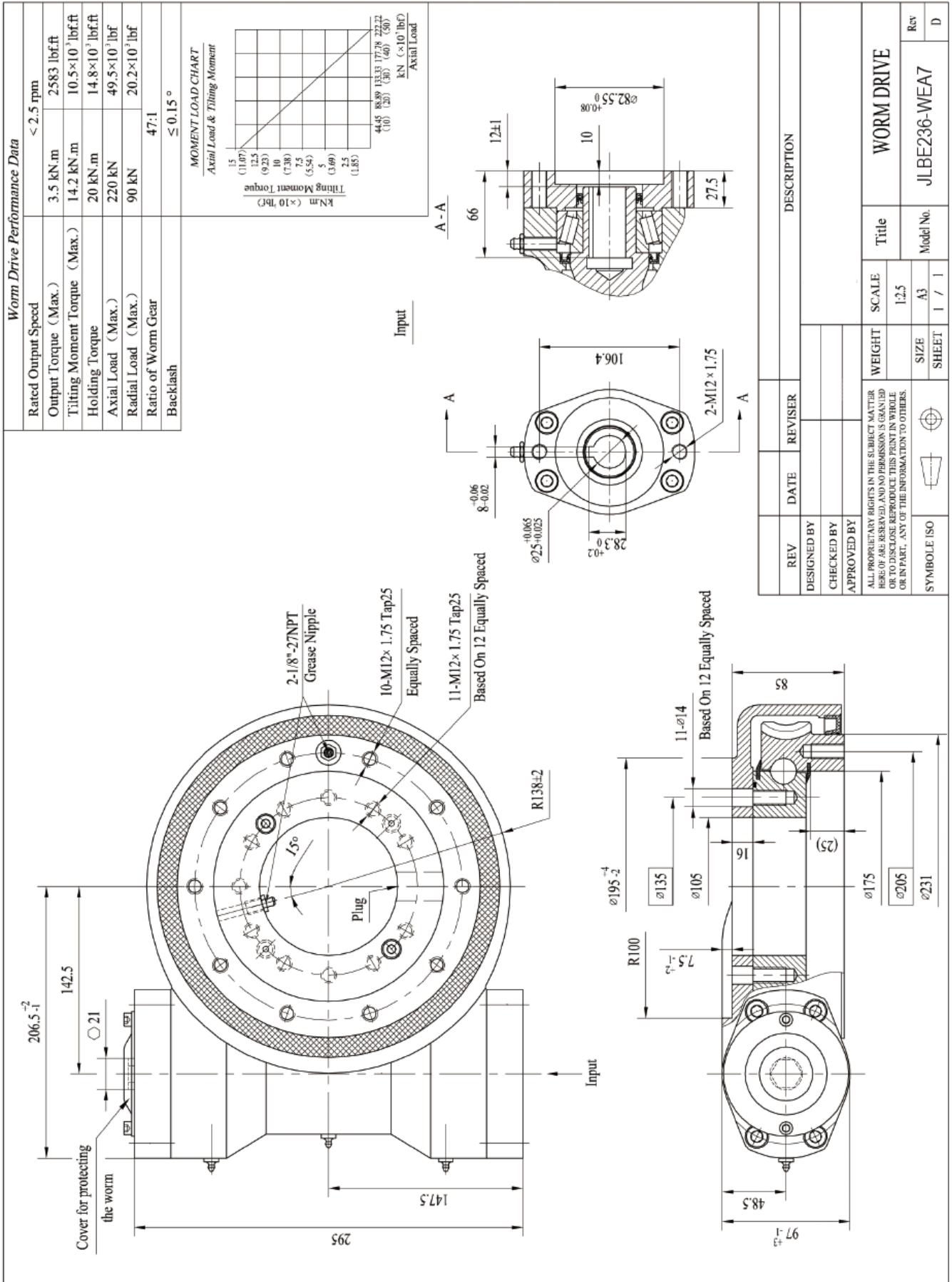

WD-9

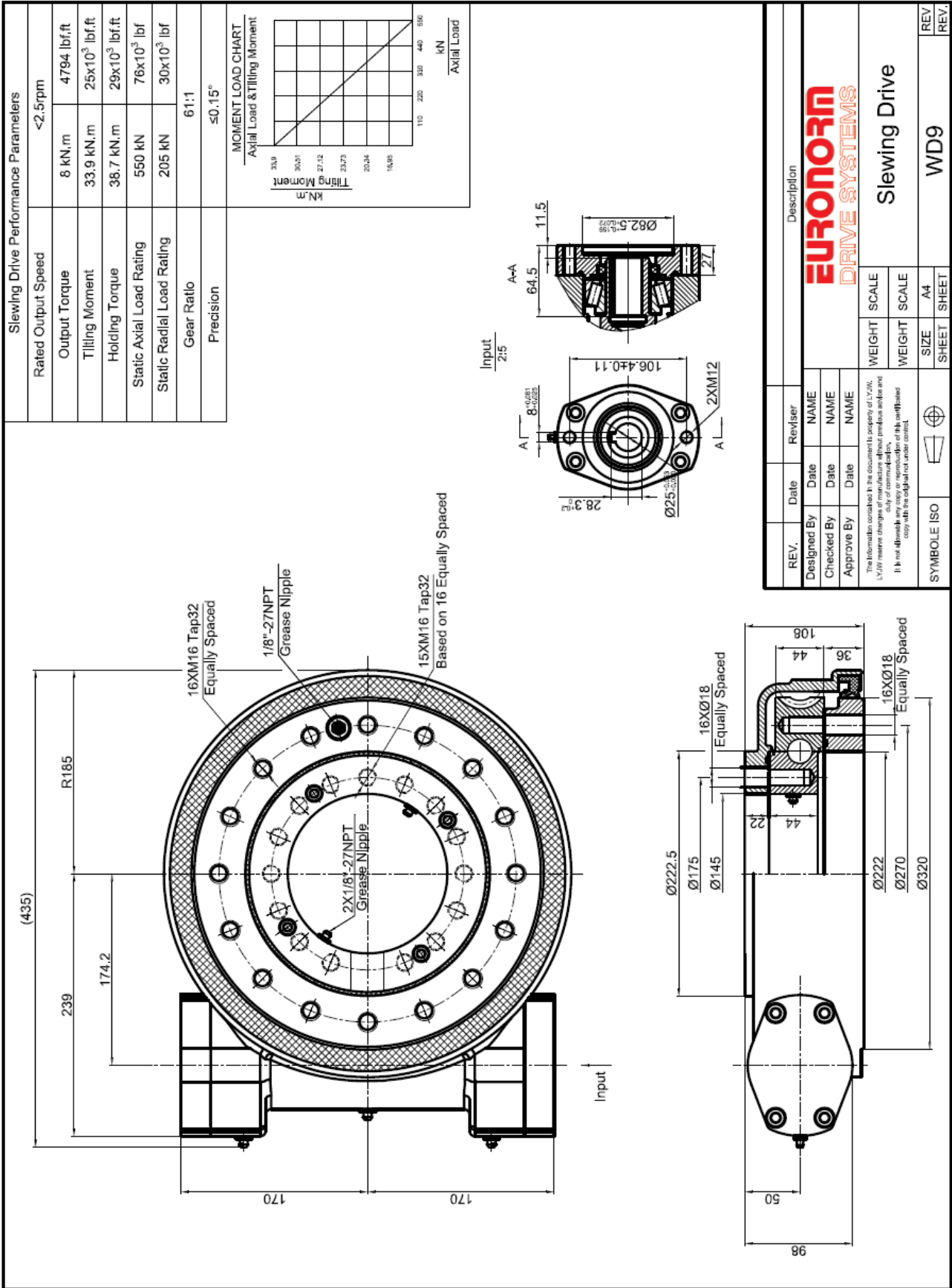

WEA-9

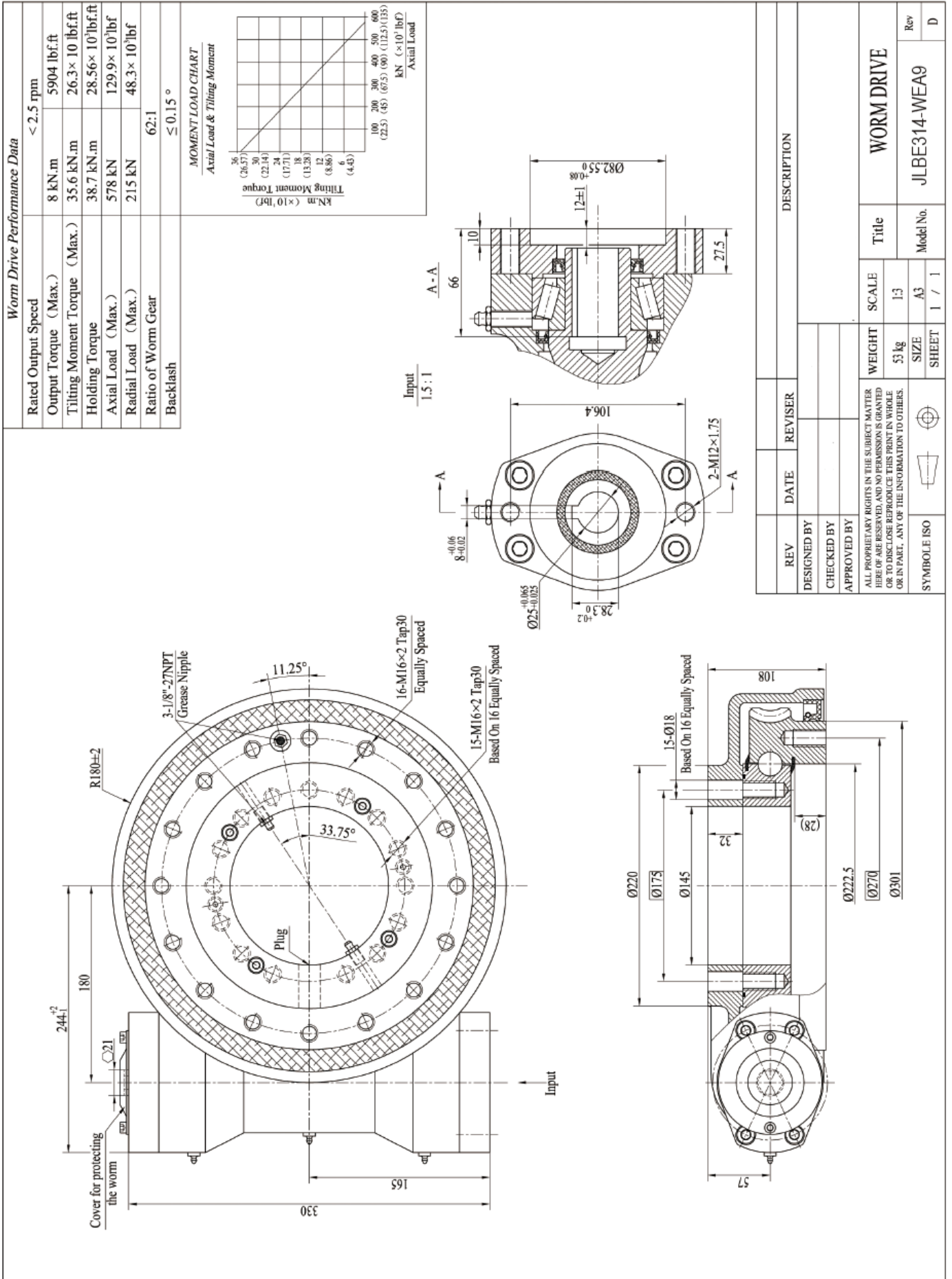

WD-14

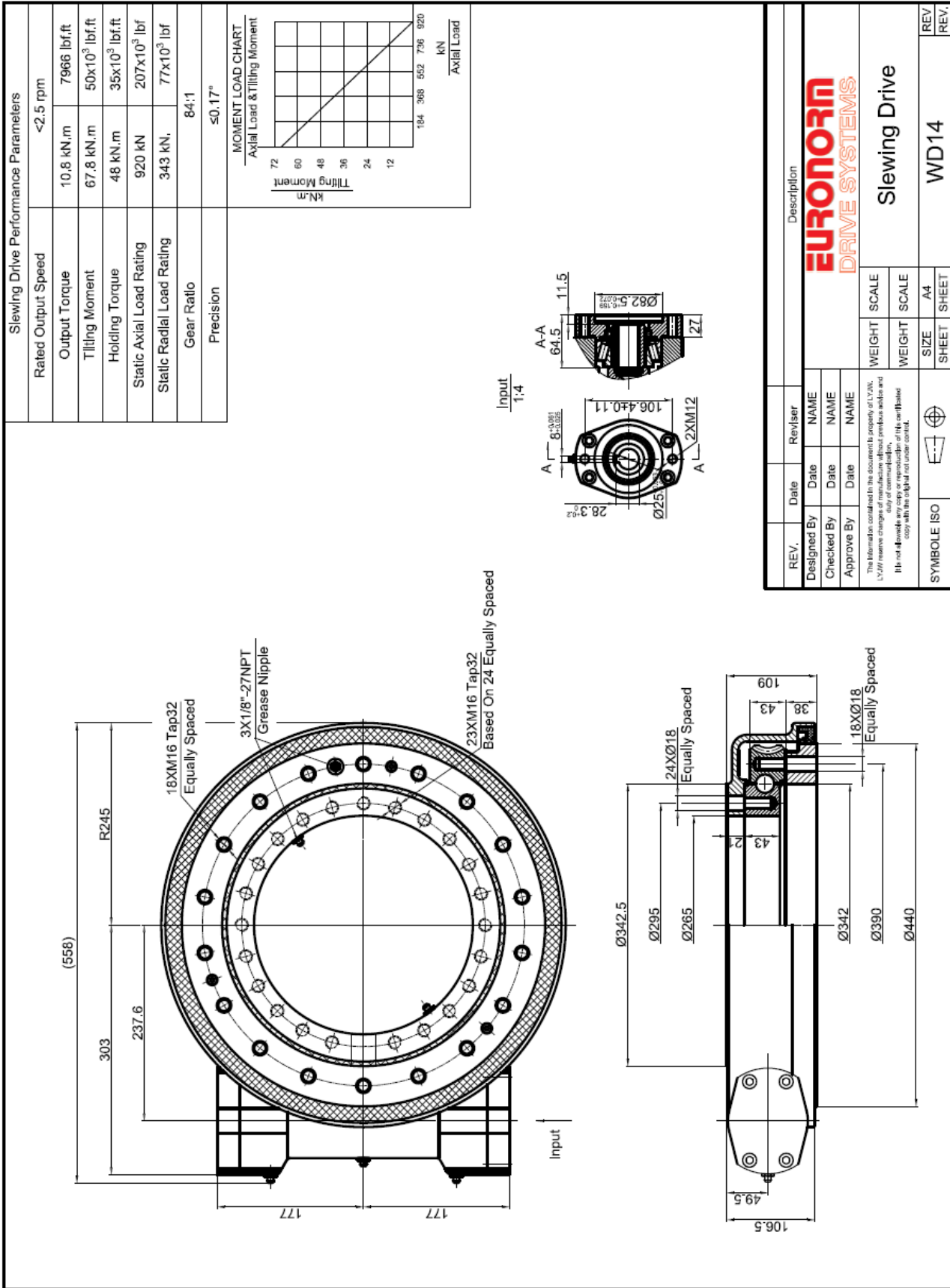

| REV. | Date | Reviser | Description |
|------|------|---------|-------------|
| | | | |
| | | | |
| | | | |

| Designed By | Date | NAME |
|-------------|------|------|
| | | |
| | | |
| | | |

| Checked By | Date | NAME |
|------------|------|------|
| | | |
| | | |
| | | |

| Approve By | Date | NAME |
|------------|------|------|
| | | |
| | | |
| | | |

The information contained in this document is property of VZW LVM. LVM reserves the right to change the design without notice and without liability. It is not intended to be used for any other purpose than the one for which it was designed.

| SYMBOL | ISO | SIZE | SHEET |
|--------|-----|------|-------|
| | | A4 | |
| | | | |

| WEIGHT | SCALE |
|--------|-------|
| | |
| | |

| SYMBOL | ISO | SIZE | SHEET |
|--------|-----|------|-------|
| | | A4 | |
| | | | |

| WEIGHT | SCALE |
|--------|-------|
| | |
| | |

EURONorm
DRIVE SYSTEMS

Slewing Drive

| REV. | REV. |
|------|------|
| | |
| | |

| REV. | REV. |
|------|------|
| | |
| | |

WD14

WEA-14

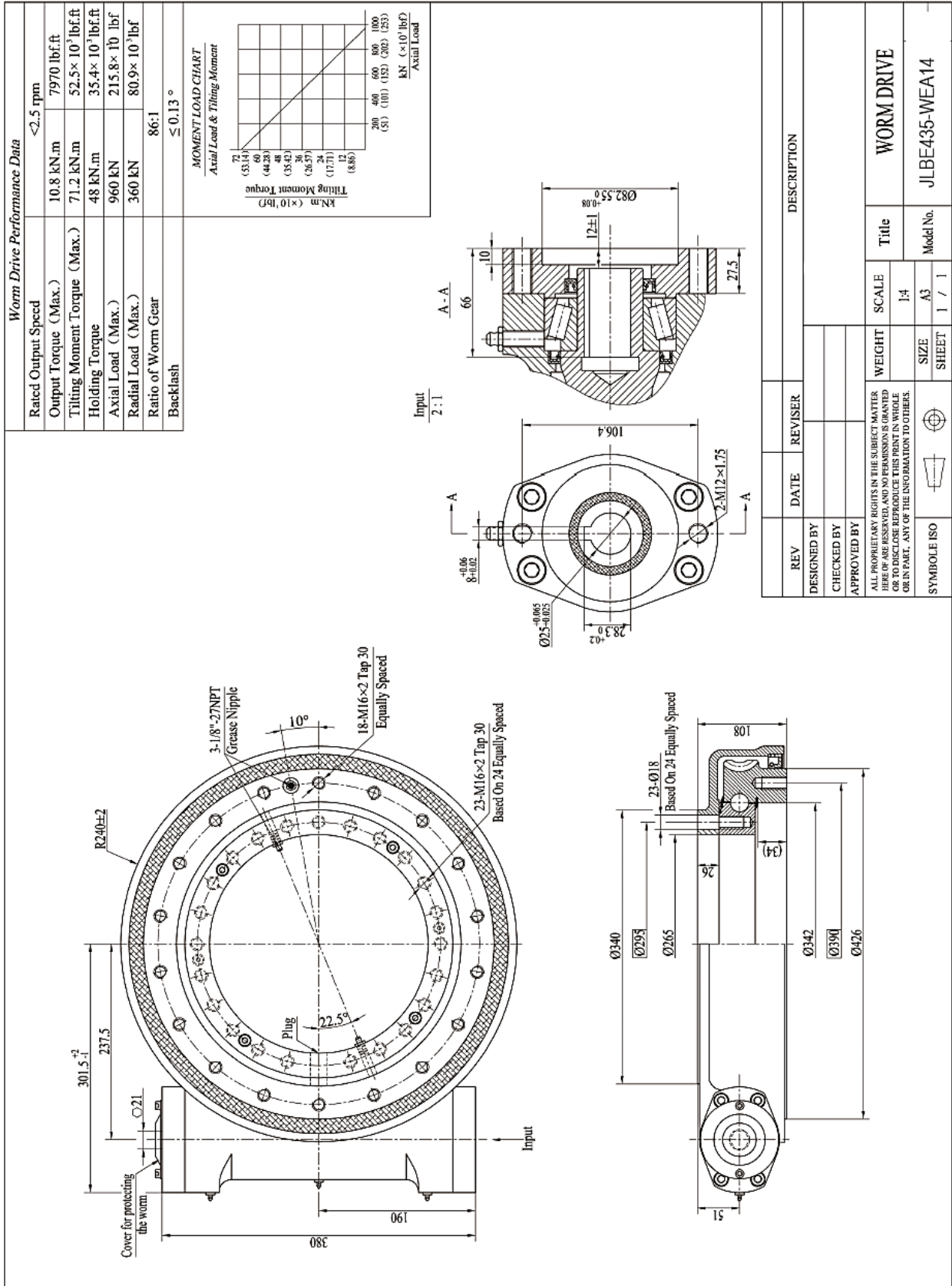

WD-17

| Slewing Drive Performance Parameters | |
|--------------------------------------|--|
| Rated Output Speed | <2.5 rpm |
| Output Torque | 12.9 kN.m 9515 lbf.ft |
| Tilting Moment | 135.6 kN.m 100x10 ³ lbf.ft |
| Holding Torque | 72.3 kN.m 53x10 ³ lbf.ft |
| Static Axial Load Rating | 1110 kN 250x10 ³ lbf |
| Static Radial Load Rating | 414 kN 93x10 ³ lbf |
| Gear Ratio | 99:1 |
| Precision | ±0.1° |

Input
1:4

| Description | |
|----------------------------------|---------------|
| EURONORM DRIVE SYSTEMS | Slewing Drive |
| WEIGHT SCALE | SCALE |
| WEIGHT SCALE | SCALE |
| SIZE A4 | SIZE A4 |
| SHEET | SHEET |
| REV | REV. |
| WD17 | WD17 |

WEA-17

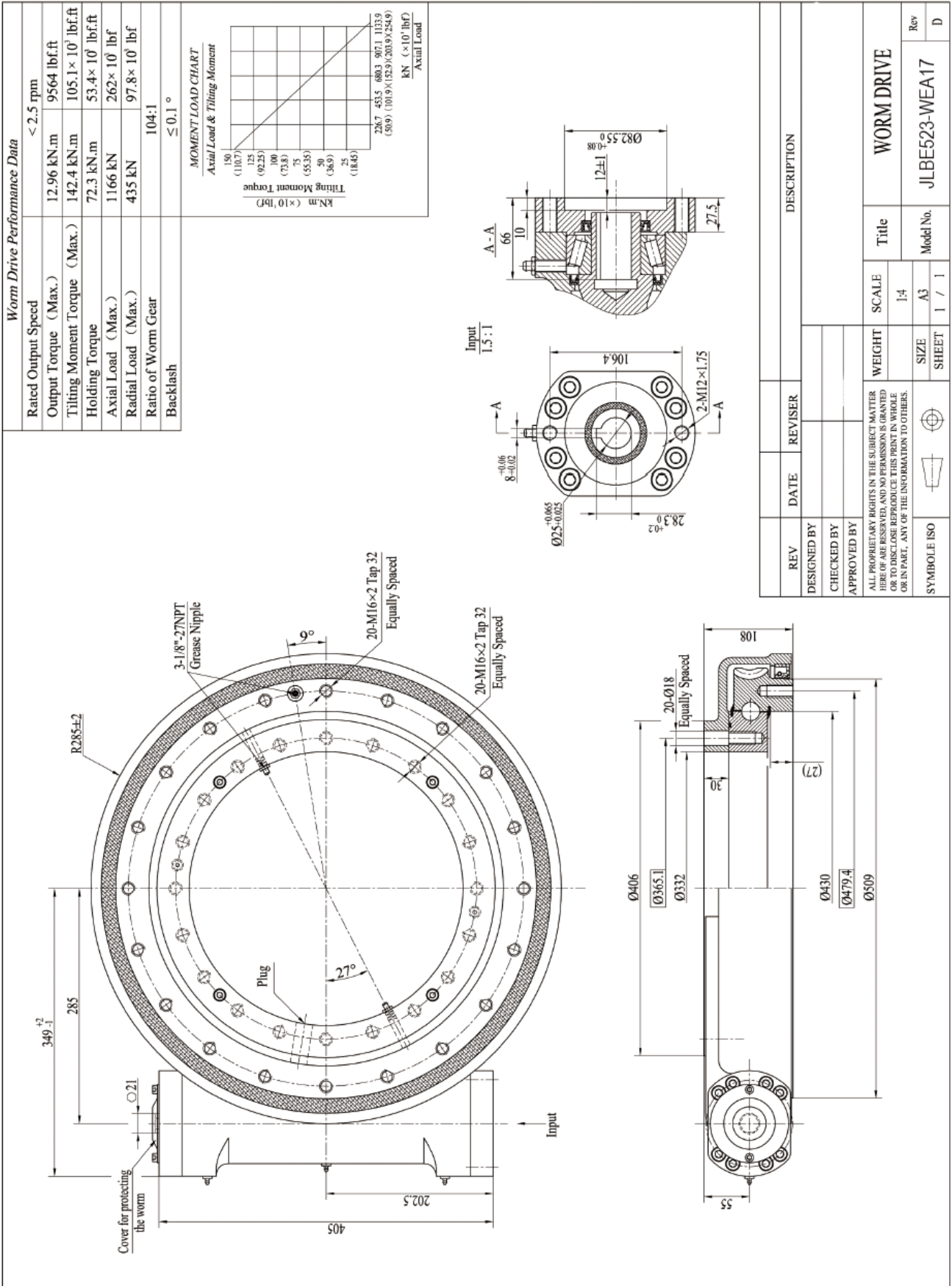

WD-19

| Slewing Drive Performance Parameters | |
|--------------------------------------|--|
| Rated Output Speed | <2.5rpm |
| Output Torque | 25 kN.m 18440 lbf.ft |
| Tilting Moment | 203.4 kN.m 150x10 ³ lbf.ft |
| Holding Torque | 35.5 kN.m 26x10 ³ lbf.ft |
| Static Axial Load Rating | 1806 kN 407x10 ³ lbf |
| Static Radial Load Rating | 675 kN 152x10 ³ lbf |
| Gear Ratio | 92:1 |
| Precision | ±0.17° |

| REV. | DATE | NAME | DESCRIPTION |
|------|------|------|-------------|
| | | | |

| REV. | DATE | NAME | REVISOR |
|------|------|------|---------|
| | | | |

| DESIGNED BY | DATE | NAME |
|-------------|------|------|
| | | |

| CHECKED BY | DATE | NAME |
|------------|------|------|
| | | |

| APPROVED BY | DATE | NAME |
|-------------|------|------|
| | | |

The information contained in this document is the property of EURONorm. It is not to be used, copied, reproduced, or disseminated in any form without the prior written consent of EURONorm. It is not allowed to make any copy or reproduction of this certified copy with the original not under control.

| SYMBOL | ISO | SCALE |
|--------|-----|-------|
| | | |

| WEIGHT | SCALE |
|--------|-------|
| | |

| WEIGHT | SCALE |
|--------|-------|
| | |

| SIZE | A3 |
|------|----|
| | |

| SHEET | SHEET |
|-------|-------|
| | |

| DESCRIPTION | REV. |
|----------------------------------|------|
| EURONorm DRIVE SYSTEMS | |
| Slewing Drive | |
| WD19 | |

WD-25

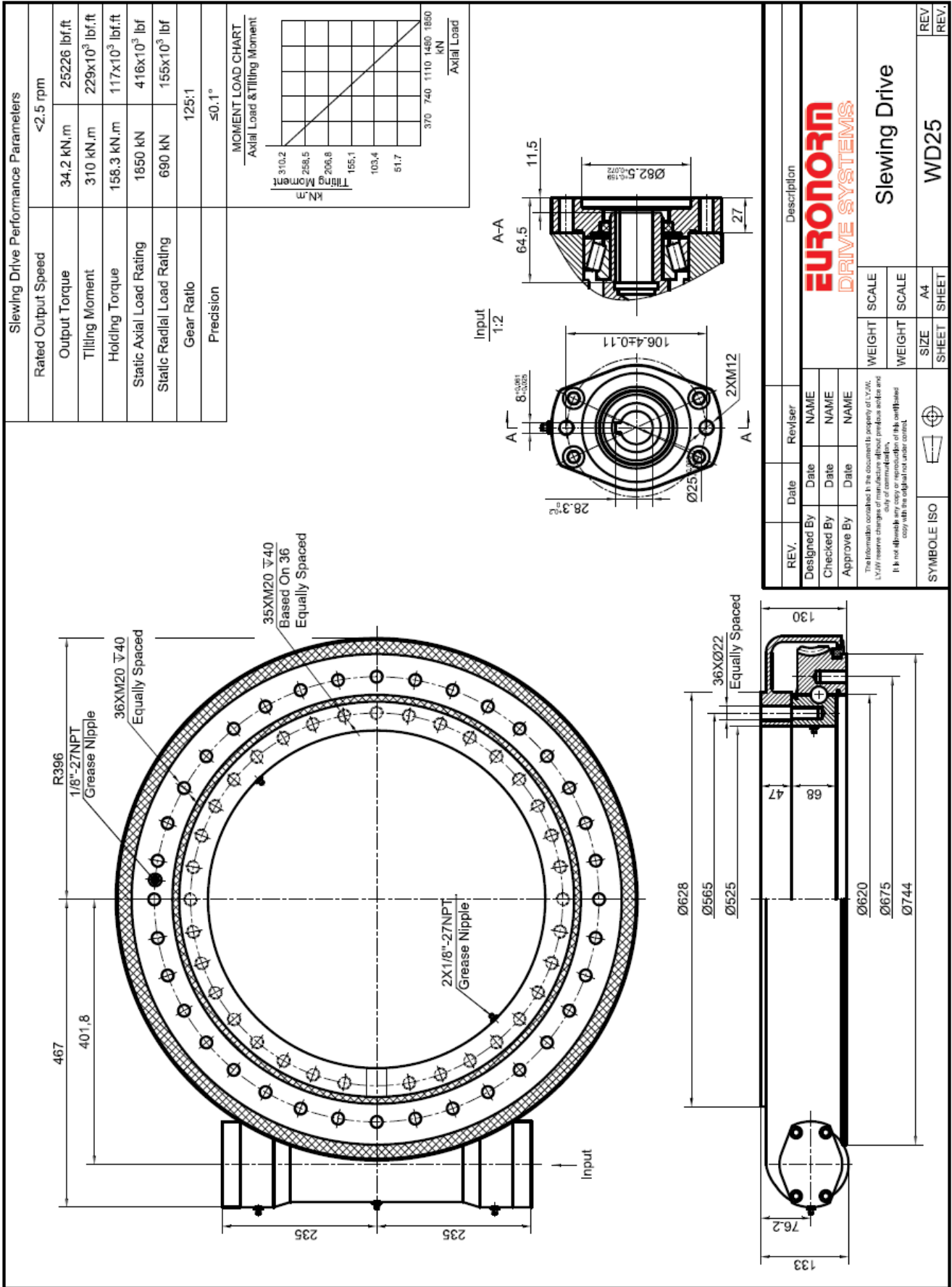

WEA-25

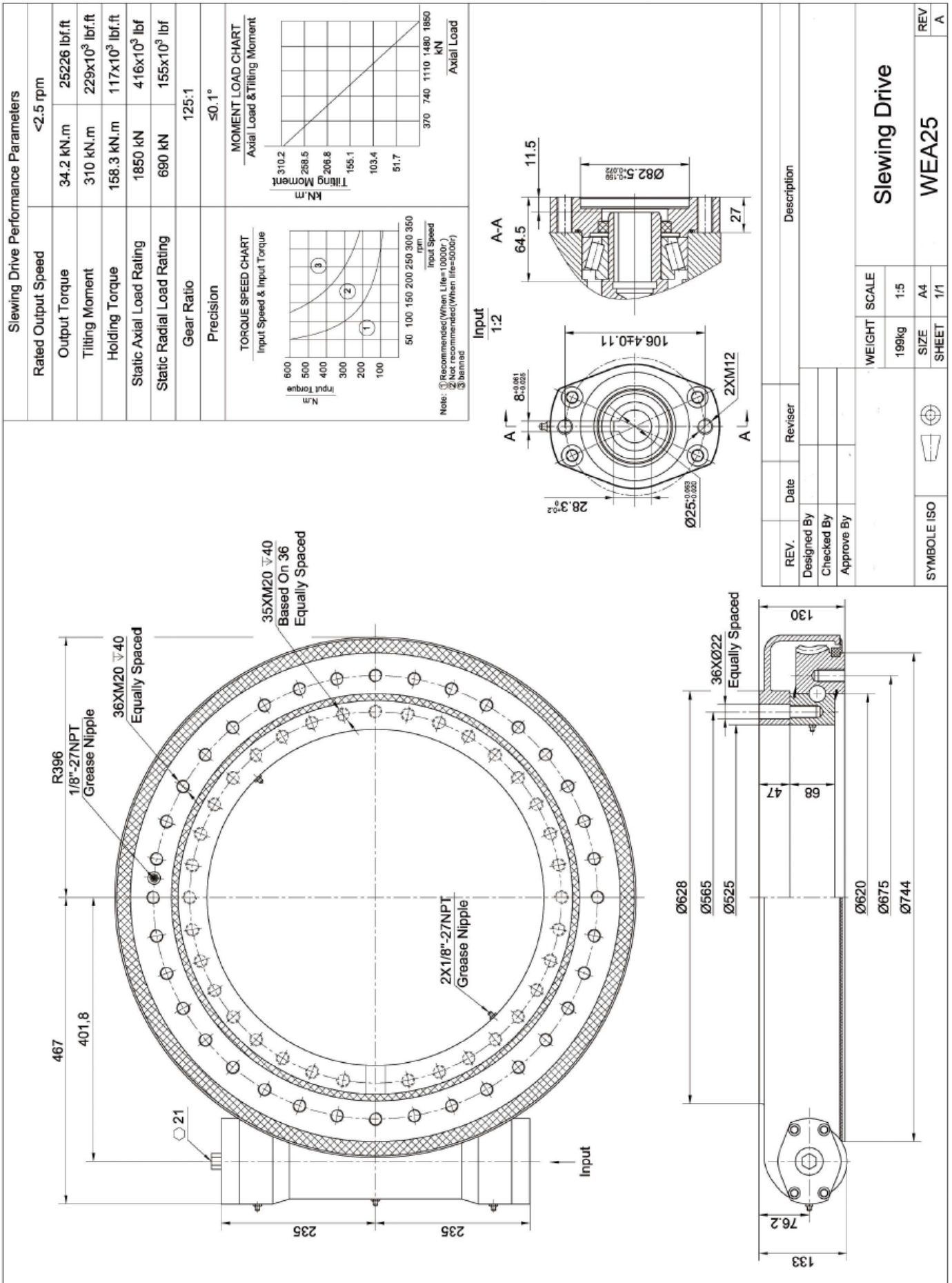

WD-37

